



Installation Instruction



For safety reasons, we kindly ask you to read the installation and user guide before fitting and using the product. The installation shall be carried by a licensed electrician. The luminaire must be permanently installed in the electric system and placed in the correct zone.

This installation instruction applies to the following models:

- ID-X5-C
- ID-X5-MB

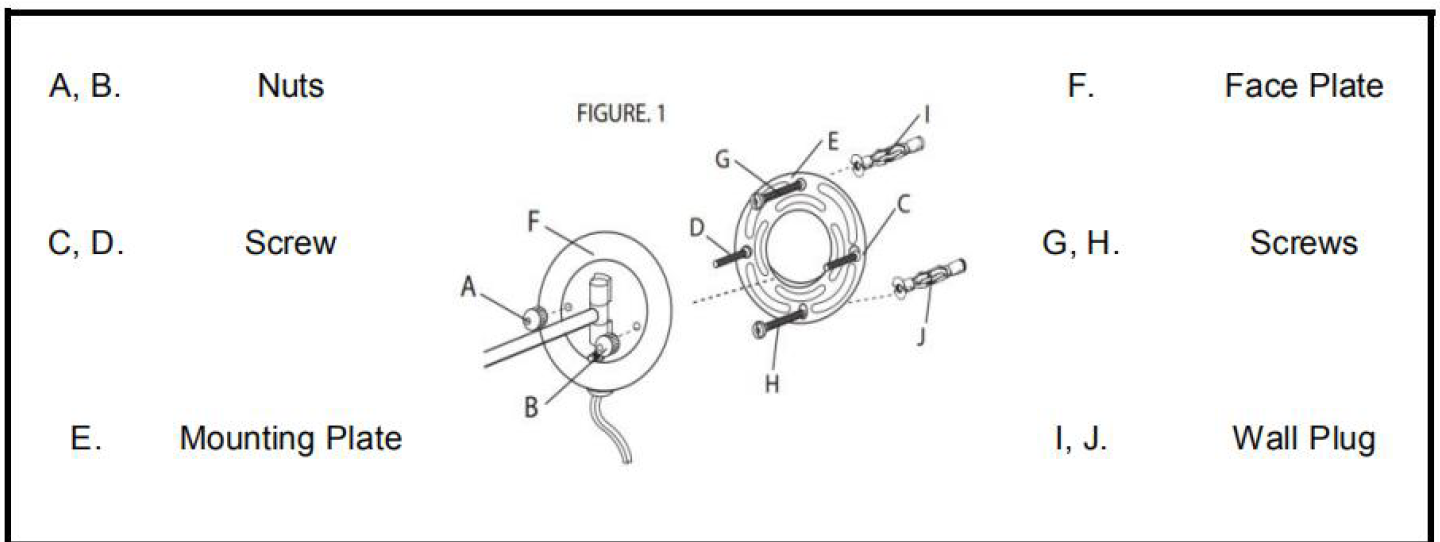

Installation Instruction (See FIG.1)

1. Begin by determining the appropriate location and height. Recommended approximately 150cm from the floor if mirror is to be used while standing, and 120cm from the floor for use while seated.
2. Remove nuts A and B from screw C and D. Separate mounting plate E and face plate F.
3. Use the mounting plate E as a template to mark the holes on the wall. Notice: Be sure to position mirror near electrical outlet.
4. Drill the two holes and insert wall plug.
5. Caution: Please use appropriate type of anchors/plugs for each type of surface.
6. Remove screws G and H from wall plug I and J.
7. Holding mounting plate into the position, thread screws G and H through mounting plate into wall.
8. Place face plate F over mounting bracket by aligning holes with screws C and D and secure with nuts A and B.



Care and Cleaning

1. Use appropriate wall fixing for your wall type.
2. Switch off the electrical supply at the mains before the installation and maintenance.
3. Do not leave the mirror on for prolonged period.
4. For cleaning and maintenance, wipe the mirror surface with a few drops of methylated spirits or isopropyl alcohol on a slightly damp cloth.
5. Do not use any abrasive cleaner any surface.
6. Do not turn on the mirror until you make sure the mirror is completely dry.
7. Do not submerge mirror in water or use excessive water for cleaning.